

A CUT ABOVE THE REST

Inside clamping beveling machine type US 150



The US 150 portable pipe beveling tool is designed for high quality portable beveling, facing and machining on pipe and tube from 150 to 508 mm pipe sizes (5.9" to 20").

The standard tool plate will accept multiple tool bits, allowing up to four simultaneous machining operations. Such operations may include beveling and OD chamfering.

The US 150 features a self-accepting torque system and an integral dual right angle pneumatic drive.

The rugged US 150 is capable of performing repeatable high quality weld preparations on all machinable alloy pipes including stainless steel, duplex, superduplex, inconel, etc.

TECHNISCHE DATEN:

Machining capacity:	150 mm ID – 508 mm OD
Clamping capacity:	150 mm ID – 508 mm ID
Clamping:	manual, with key
Expansion :	30 mm
Feed:	manual feed, 100 mm travel
Weight :	90 kg (with pneumatic drive)
Dimensions:	please see drawing
RPM:	Off-load speed: 7 to 10 rpm Nominal speed: 5 to 7 rpm
Drive:	pneumatic drive
Power:	2 x 1,5 kW
Working pressure:	6 bar
Air intake:	2200 l/min per Motor
Optional equipment:	see back of the data sheet

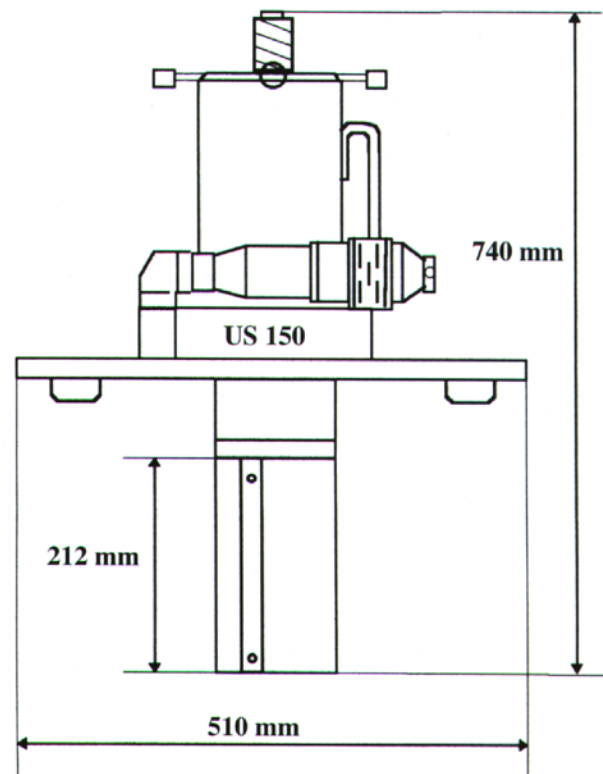

This machine must be equipped with a lubricating filter !

Subject to technical modification without prior information !

Similar illustration

A CUT ABOVE THE REST

OPTIONAL EQUIPMENT:

- Electric drive
- Hydraulic drive
- Flange facing attachment
- Elbow mandrel assembly
- Enveloping jaws for thin wall (< 8 mm)
- Jaws of stainless steel or on specifications
- Tool holder plate 24"(610 mm)

For more information on specific applications, please call Protem.