

## A CUT ABOVE THE REST

### Outside clamping tube and fittings facing machine type SE 65



The SE 65 is specially designed for squaring in position from 9,52 mm ID to 63,5 mm OD.

The tool holder plate equipped with 2 tool inserts allows to cover the machining range without any adjustment.

The set up of the tube is carried out quickly through a monobloc collet.

The machine features a graduated vernier which gives a high quality and accurate weld prep.

### TECHNICAL FEATURES:

<b>Machining capacity:</b>	12,7 mm OD – 63,5 mm OD 1/2" OD – 2 1/2" OD
<b>Clamping capacity:</b>	12,7 mm OD – 63,5 mm OD 1/2" OD – 2 1/2" OD
<b>Clamping:</b>	manual, with clamping lever
<b>Feed:</b>	Graduated manual feed 1 div. = 0,1 mm / 0.004"
<b>Weight:</b>	3,5 kg
<b>Dimensions:</b>	Please see drawing
<b>RPM:</b>	Level 1: 0 – 500 rpm Level 2: 0 – 1500 rpm
<b>Drive:</b>	cordless electric drive 14,4 V / 2,0 Ah
<b>Optional equipment:</b>	<ul style="list-style-type: none"> <li>• Right angle drive</li> <li>• SE 25 for Ø 2 – 25,4 mm OD Ø 5/64" – 1" OD</li> <li>• Electric drive 230 V</li> <li>• additional clamping head for angled ends of tubes</li> </ul>

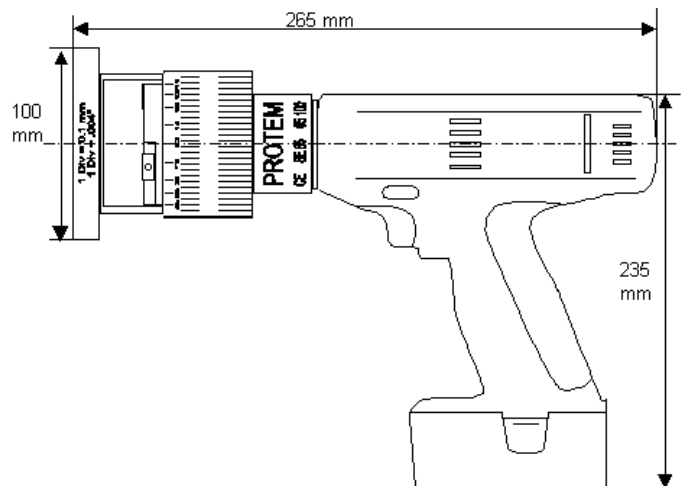

Expansion collets: • for inch. diameters  
• for mm diameters  
• extra short collets for Microfittings

Subject to technical modification without prior information !