

## A CUT ABOVE THE REST

### Outside clamping tube and fittings facing machine type SE 25 RA



The portable machine SE 25 RA is specially designed for facing in position the diameters from 2 mm to 25,4 mm **under tight places of work**.

The tool holder plate equipped with one tool insert allows to cover the machining range without any adjustment.

The set up of the tube is carried out quickly through a stainless steel monobloc collet.

The machine features a graduated vernier which gives a high quality and accurate weld prep.

### TECHNICAL FEATURES:

<b>Machining capacity:</b>	2 mm OD – 25,4 mm OD 5/64" OD – 1" OD
<b>Clamping capacity:</b>	2 mm OD – 25,4 mm OD 5/64" OD – 1" OD
<b>Clamping:</b>	manual, with clamping lever
<b>Feed:</b>	Graduated manual feed 1 div. = 0,1 mm / 0.004"
<b>Weight:</b>	2,5 kg
<b>Dimensions:</b>	please see drawing
<b>RPM:</b>	Level 1: 0 – 400 rpm Level 2: 0 – 1250 rpm
<b>Drive:</b>	cordless electric drive 12 V / 1,4 Ah
<b>Optional equipment:</b>	SE 65 for Ø 12,7 - 63,5 mm OD Ø 1/2" – 2 1/2" additional clamping head for angled ends of tubes SE25 standard version with in line cordless electric drive
<b>Expansion collets:</b>	<ul style="list-style-type: none"> <li>• for inch. diameters</li> <li>• for mm diameters</li> <li>• extra short collets for Microfittings</li> </ul>

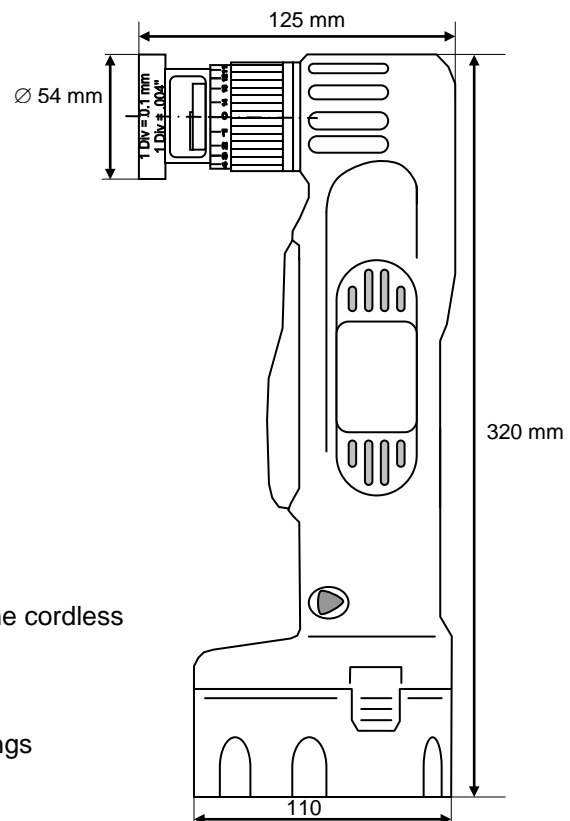

Subject to technical modification without prior information !